

集塵組 Waste Lint Remoal

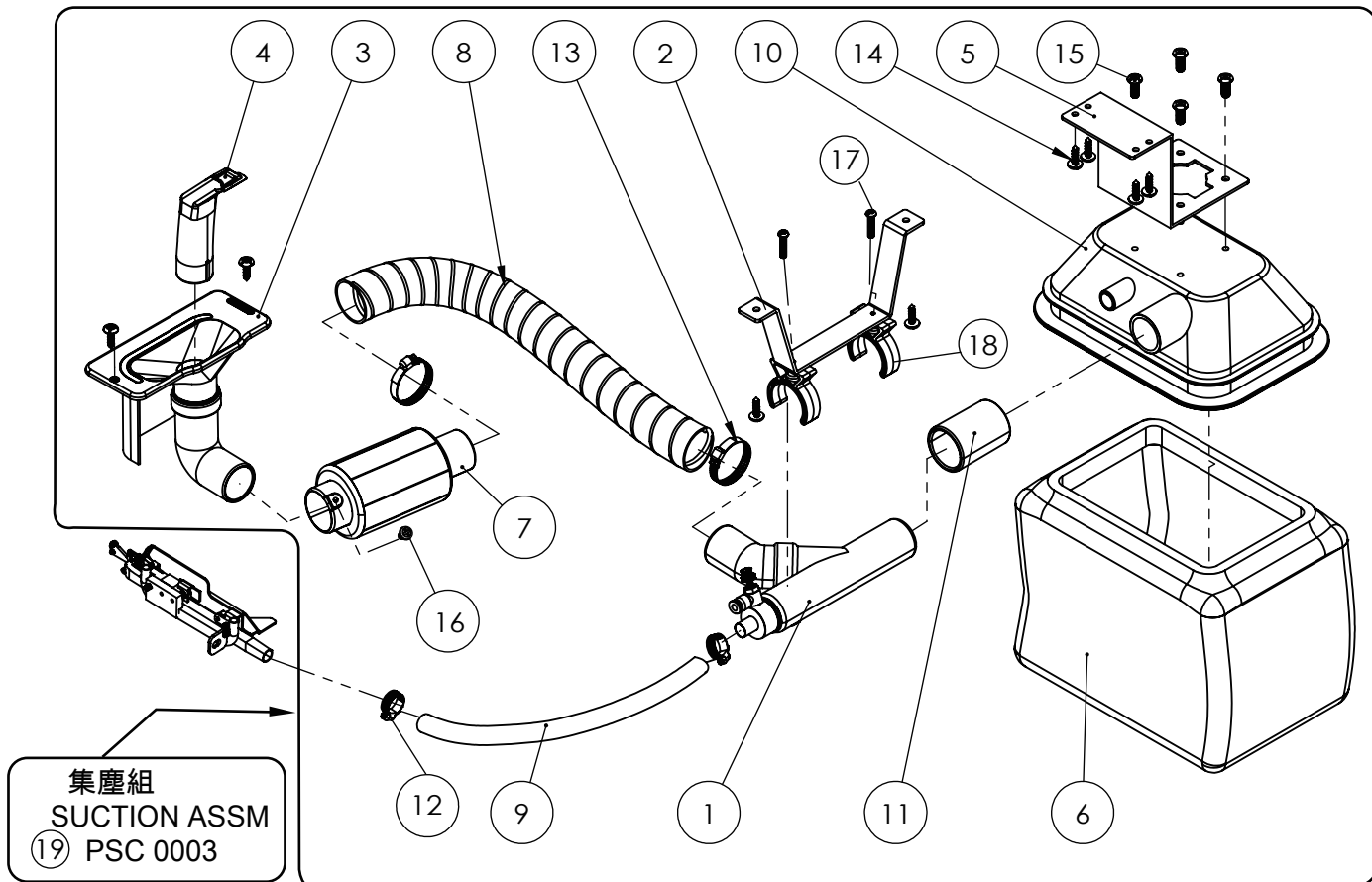

項次 NO.	件號 Part NO.	名稱	Description	數量 Amt. Req
1	SCU 0001	大文氏管	VENTURI TUBE - BIG	1
2	SCU 0002	大文氏管支架組	VENTURI TUBE BRACKET	1
3	SCU 0004	集布屑漏斗	WAST LINT REMOVAL FUNNEL	1
4	SCU 0005	集布屑漏斗管	WAST LINT REMOVAL PIPE	1
5	SCU 0006	集塵桶支架	WAST LINT REMOVAL BRACKET	1
6	SCU 0007	集塵袋	BAG	1
7	SCU 0008	消音器	MUFFLER	1
8	SCU 0009	螺旋管	SPIRAL TUBE	1
9	SCU 0010	透明管	TRANSPARENT TUBE	1
10	SCU 0011	集塵桶	WAST LINT REMOVAL COVER	1
11	SCU 0012	軟管	HOSE	1
12	SCU 0013	13-19束子	COLLAR 13-19	2
13	SCU 0014	21-44束子	COLLAR 21-44	2
14	WAB 0001	木螺絲	SELF TAPPING SCREWS	8
15	MHS 0015	螺絲M6x10	SCREW M6x10	4
16	MDB 0002	螺絲 M5X7	SCREW M5X7	1
17	MDX 0009	螺絲 M4X18	SCREW M4X18	2
18	SCU 0055	C型座	BRACKRT	2
19	PSC 0003	集塵組	SUCTION ASSM	1

電磁閥及氣壓錶

Solenoid Valve And Air Regulator

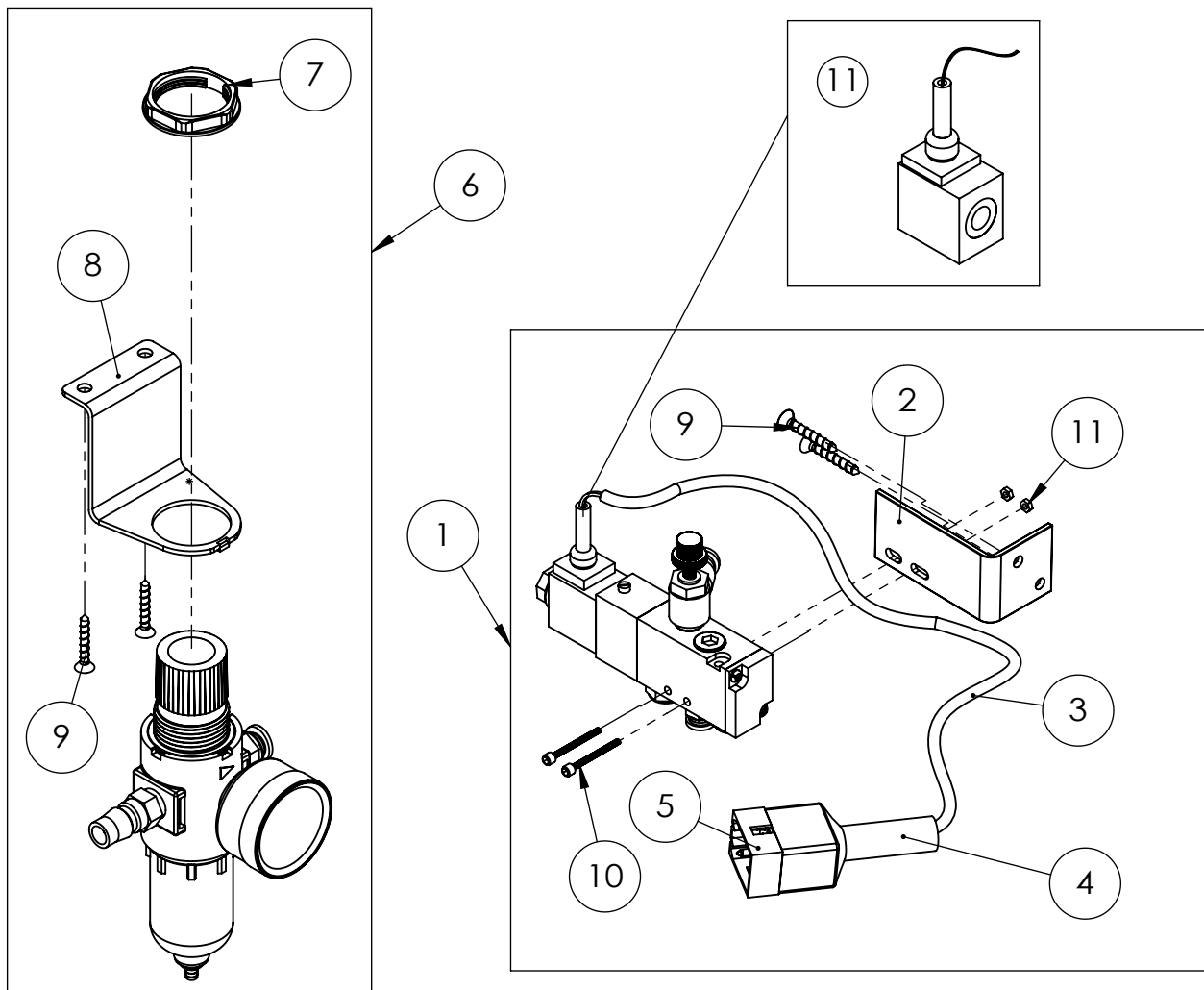

項次 NO.	件號 Part NO.	名稱	Description	數量 Amt. Req
1	PNC 0010	電磁閥	SOLENOID VALVE	1
2	PNC 0038	電磁閥支架	SOLENOID VALVE BARCKET	1
3	PLG 0003	纏繞管	SPIAL WRAPPING BAND	1
4	PLG 0002	插頭保護套	CONNECTOR COVER	1
5	PLG 0001	插頭	CONNECTOR	1
6	PNC 0015	氣壓錶	AIR REGULATOR	1
7	PNC 0018	氣壓錶螺帽	AIR REGULATOR NUT	1
8	PNC 0017	氣壓錶座	AIR REGULATOR BARCKET	1
9	WAB 0001	木螺絲	SELF TAPPING SCREWS	2
10	MHS 0022	螺絲 M2X25	SCREW M2X25	2
11	MBA 0002	螺帽	NUT	1
12	WAB 0002	木螺絲	SCREWSELF TAPPING SCREWS	2
13	PNC 0040	線圈	COIL	1

管路配置圖

Air piping diagram

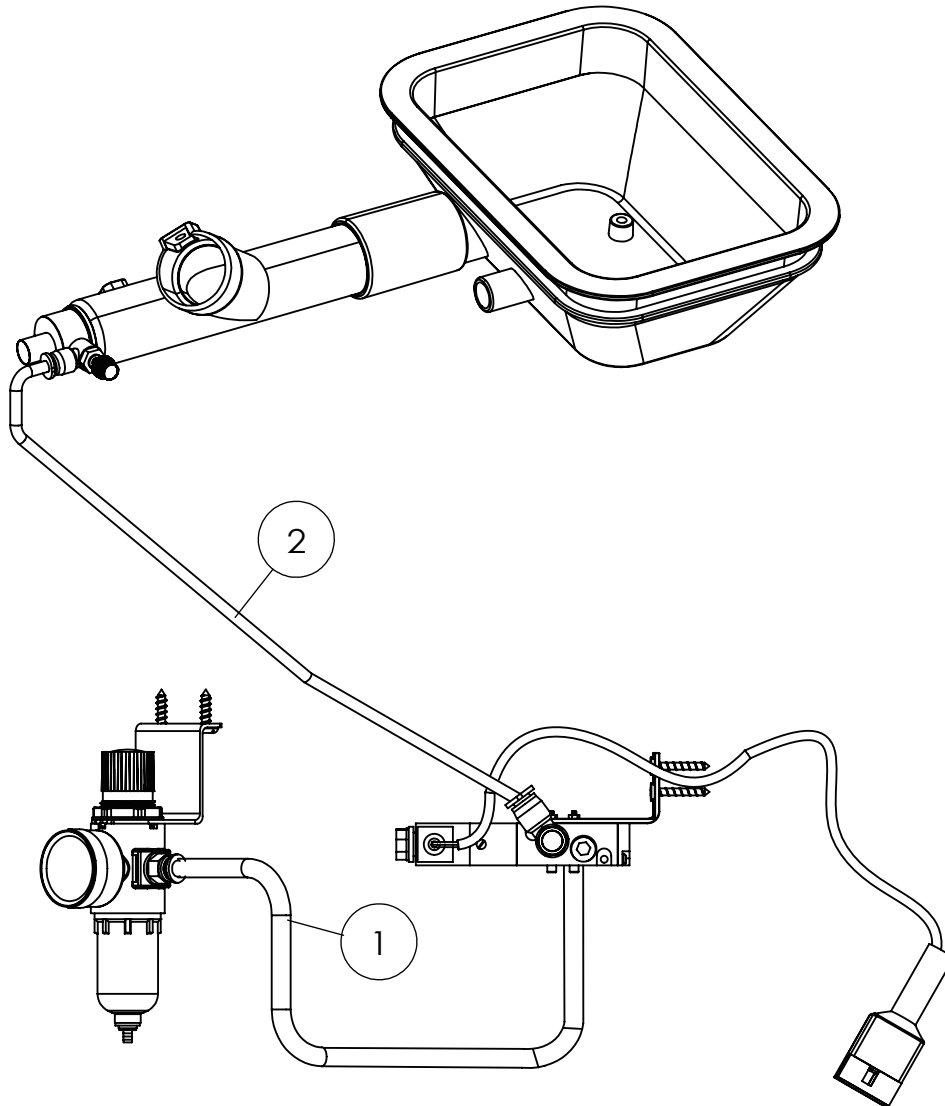

空氣壓力：標準0.5Mpa (5kgf/cm²)

可用範圍：0.45-0.55Mpa

Air pressure：標準0.5Mpa (5kgf/cm²)

Usable range：0.45-0.55Mpa

項次 NO.	件號 Part NO.	名稱	Description	數量 Amt. Req
1	PNC 0005	6號黑管 x 60 cm	BLACK PNEUMATIC TUBE #6 x 60 cm	1
2	PNC 0005	6號黑管 x 85 cm	BLACK PNEUMATIC TUBE #6 x 85 cm	1